



CL & CLG Clamp Mount Mixers

OWNERS MANUAL

Warranty

Our products are guaranteed against defective materials and workmanship, we will repair or replace such items as may prove defective at our option. Warranty period is one year on items manufactured by INDCO, except for the MixMaster Series Shakers which carries a two year warranty. On items not manufactured by INDCO, the manufactures warranty applies. All component parts of our products are covered by this warranty, except for normal wear items such as belts or impellers. We cannot be responsible for damage or abuse to equipment caused by improper installation or operation. Warranties can also be voided by unauthorized disassembly of equipment. For warranty repairs, equipment is returned to INDCO at the customer's expense; we will repair and return to customer at our expense. Under no circumstances will we allow labor charges or other expense to repair defective merchandise. This warranty is exclusive and is in lieu of all other warranties, whether express or implied. INDCO shall not be liable for any other damages, whether consequential, indirect, or incidental, arising from the sale or use of its products.

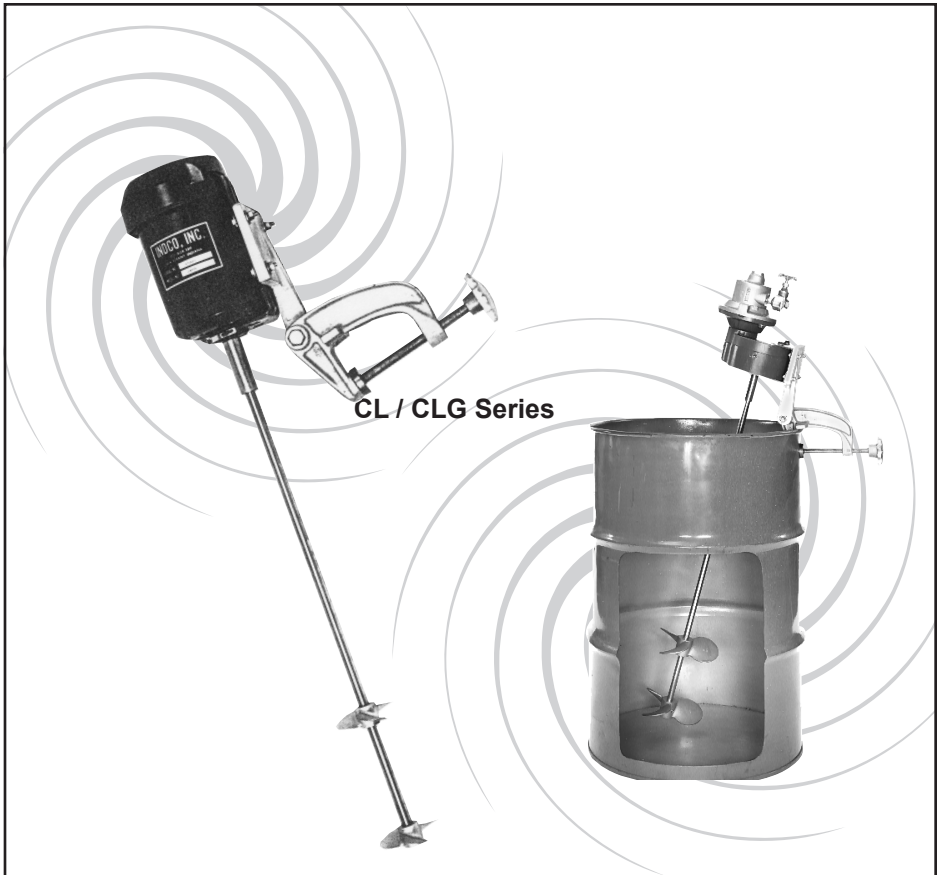

CL / CLG Series
**CL & CLG SERIES
CLAMP MOUNT MIXERS**

Contents:

	Page:
Model - Drawing Data	2
Safety & General & Receiving.	3
Installation	4
Operation	5
Maintenance	5
Parts List	6



INDCO, Inc.
P.O. Box 589
New Albany, IN 47151
phone: 812-941-5954
fax: 812-944-9742
web: www.indco.com

INDCO

CL & CLG Clamp Mount Portable Mixer

Model: _____

Serial No.: _____

Date: _____

Order No.: _____

100 - Motor:

Part No.: _____

HP: _____ RPM: _____

volts: _____ cycles: _____ phase: _____

frame: _____ enclosure: _____

300 - Shaft:

Diameter _____

• Total length _____

• Length exposed _____

200 - Gear Box:

G.Box Part No.: _____

RPM output _____

400 - Impellers:

Diameter _____

Type _____

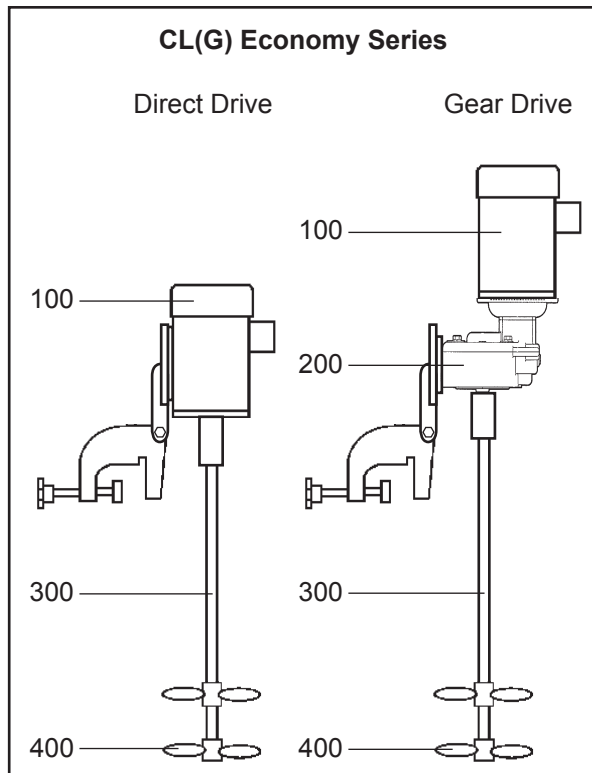

Safety

Please follow the below safety precautions. If there are any questions, please call INDCO at 800-942-4383.

Please read this complete manual before trying to operate your mixer. Failure to follow these instructions could result in serious bodily injury or death.

- Do not touch moving parts while mixer is operating. Do not wear loose-fitting clothes or jewelry around an operating mixer. Keep all hands, feet, clothes, neckties, necklaces and other objects clear of moving parts.
- Never move the unit without a suitable lifting device.
- Have a qualified individual bring power to your unit.
- Always ground the unit. Never use an extension cord.
- Never run the unit in open air.
- Never adjust the speed without the unit running.
- Always lockout the power when working on the unit.

Electric Motor Safety:

Motors should be installed, protected and fused in accordance with latest issue of National Electrical Code, NEMA Standard Publication No. MG 2 and local codes.

Frames and accessories of motors should be grounded in accordance with National Electrical Code (NEC) Article 430. For general information on grounding refer to NEC Article 250.

Not all rotating parts are guarded. Keep hands and clothing away from moving parts.

Trained, qualified personnel should make electrical repairs and non-standard connections.

If environment has hazardous combustible fumes present, use only explosion-proof electric motors.

Air Motor Safety:

The air motor is designed to be driven by compressed air and under no circumstances be driven with any other gases. Fluids, particles, solids or any substance mixed with air, particularly combustible substances likely to cause explosions, must not drive air motor.

- Do not drive with flammable or explosive gases or operate unit in an atmosphere containing them.
- Air motor is designed for air only. Do not allow corrosive gases or particulate material to enter motor. Water vapor, oil-based contaminants, or other liquids must be filtered out.

Air Motor Safety: (continued)

- Ambient temperature should not exceed 250°F.
- Beware of any exposed and/or movable parts. Proper guards should be in place to prevent personal and/or property damage.
- Solid or liquid material exiting unit can cause eye or skin damage. Keep away from air stream.
- Always disconnect air supply before servicing.
- Do not allow air motor to “run free” at high speeds with no loads. Excessive internal heat build-up, loss of internal clearances and rapid motor damage will result.
- Some models may exceed 85dB(A) sound level. Hearing protection should be worn when in close proximity to these models.

General

INDCO clamp mount mixers are engineered for mixing large volumes of light and medium materials or small batches of heavy materials. The clamp mount allows 90° vertical and adjustments for the most efficient mixing position. Clamp and motor mount are cast of aluminum for high strength and they are lightweight. Propellers and shafts are stainless steel. TEFC, Explosion-Proof and Air motors are standard.

Economy Direct Drive - CL Series

- Standard electric models have output speed of 1750RPM.
- Variable speed electric motors run from 35 to 1750RPM.
- Air models run from 300 to 3000RPM.

Economy Gear Drive - CLG Series

- Standard electric models have output speed of 350RPM.
- Variable speed electric motors run from 0 to 350RPM.
- Air models run from 60 to 600RPM.

Receiving

Before removing any packing, visually inspect the exterior of the shipment for any sign of damage. Should there be any damage, bring it to the attention of the delivering UPS or truck line and note the same on the receiving ticket. Should there be damage you must place a claim with the truck line.

They are the only ones who will pay for the damage done and you are the only one who can place that claim.

Installation

Clamp Mount

After installing the impeller(s) and impeller-shaft which have to be fitted to the machine before it's operational, lower mixer into the container and lock in place with clamp assembly. Ensure the clamp is level, square, and plumb when mounted to the mixing tank. Ensure there is adequate space around the unit for cleaning, inspection and maintenance.

Illustrations below show the ideal operating angles for the CL(G) series portable clamp-mount mixers.

- The mixing shaft should be 10° to 20° off vertical.

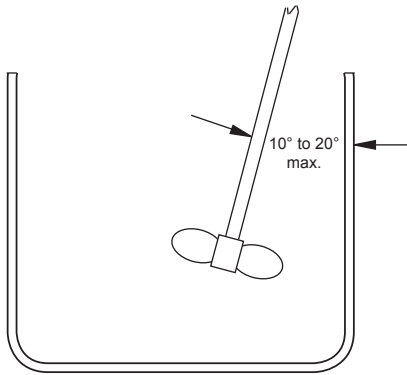

Off Vertical Mounting
CL & CLG Series

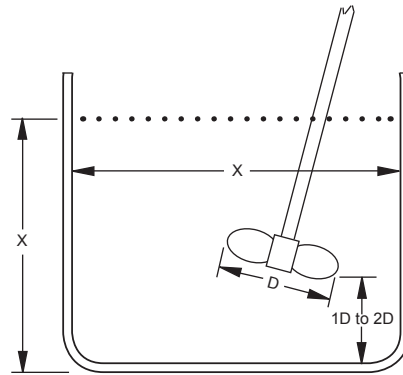

Impeller Placement
CL & CLG Series

Impellers

The standard impellers are 3-bladed marine style. To install the propeller, back off the set screw(s) as far as possible without removing them. Insert mixing shaft into the bore and tighten the set screw(s) firmly to secure the shaft to the propeller.

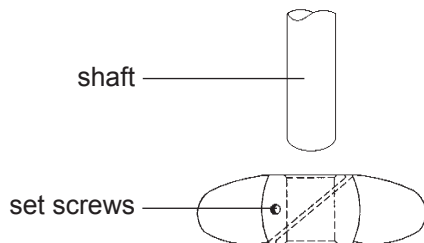

NOTE:

- Do not use a pipe wrench or any other tool to assist in tightening the hand knob(s).
- Over tightening will break the C-clamp.
- The clamp is designed to hold the mixer securely in place using hand tightness only.
- Use of tools to tighten hand knob will void the warranty.

Impeller Placement

For mixers with ONE impeller, mount it 1 to 2 impeller diameters distance off the bottom of mixing container.

For mixers with TWO or more impellers, mount the lowest impeller 1 to 2 impeller diameters distance off the bottom of mixing container. Mount the other impellers 1 to 2 impeller diameters apart. The uppermost impeller should be positioned approximately 1 impeller diameter under the surface of the liquid.

The above guide-lines are "rules of thumb" and may not be the best for your situation. Experimenting with impeller placement may provide your best results.

Installation, (continued)

Shaft & Coupler

To install mixer shaft, back off the set screws as far as possible without removing them. Insert mixing shaft into the coupler as far as it will go. Tighten the set screws firmly to secure the shaft to the coupler.

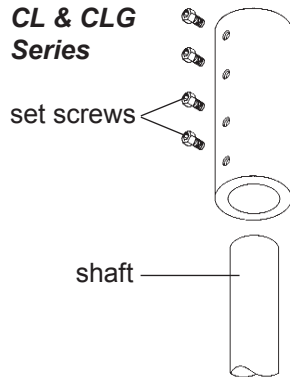

Gear Drive, Economy CLG Series

- The gear box is filled with oil.
- The brass plug supplied loose is a Filler-Vent Plug. After mounting the mixer, install the Filler-Vent Plug in the highest filler point as shown below.

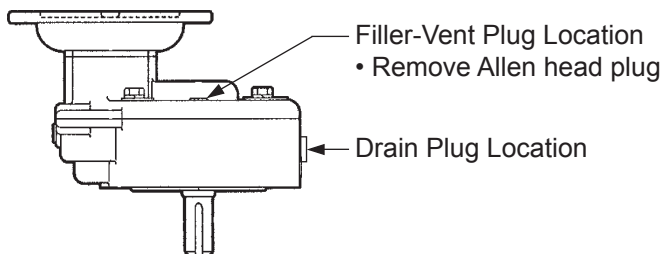

Operation

Electric Power: Once the electric motor has been wired, check rotation to be sure the mixer shaft is rotating in a clockwise direction, looking downward into the container.

Air Power: Check to ensure the air valve is in the closed position, then connect air supply. Check rotation to be sure the mixer shaft is rotating in a clockwise direction, looking downward into the container.

Once the mixer is in the container, it is now safe to operate. Always start and stop mixer in slowest speed.

CAUTION:

- **Never run mixer without a propeller.**
- **Never run the propeller in open air.**
- **Never run propeller outside a container.**

Maintenance

Maintaining your mixer is not difficult if you follow these guidelines:

- Keep the mixer clean.
- Check all set-screws and fasteners, tighten as needed.
- Check all wiring on a regular basis and repair as needed.
- Air motor powered units:
 - Keep air supply dry and oil in the lubricator.

Lubrication: (gearbox models)

Economy CLG Series:

The gear box contains oil from the factory. The recommended replacement oil is:

- Gearbox models #RPQ1 and RPQ2:
 - Mobil Extra Hecla
 - Shell Oil Omala 680
 - Texaco Meropa 680
 - or equivalent to above
 - For 50°F to 125°F ambient.
 - RPQ1 Oil capacity is 11 ounces.

Parts List - Drive Motors

NOTE: 56F "foot mount" models = CL4-T/E, CL3-T/E, CL5-T/E, CL7-T/E, CL1-T/E only.
56C "C-face mount" models = All other CL and CLG.

Item 100	Part No.	Description	
Air Motors	3/4 HP	MTR-3/4-FOOT-AIR-CCW N-K202	Foot Mount - 3/4 HP (2AM-FCC-1) CCW rotation only Repair Kit* (2AM-FCC-1)
		MTR-3/4-56C-AIR N-K510	56C Mount - 3/4 HP (2AM-NRV-90) bi-rotational Repair Kit* (2AM-NRV-90)
		HDW-1/4-VALVE	Needle valve, brass - 1/4"
		HDW-2502-SNB	Pipe nipple, steel - 1/4" x 2"
		N-AL445	Muffler, plastic
		N-AC980	Muffler, metal
		1.5 HP	MTR-1.5-FOOT-AIR N-K205
	MTR-1.5-56C-AIR N-K206A		56C Mount - 1.5 HP (4AM-NRV-50C) bi-rotational Repair Kit* (4AM-NRV-50C)
	HDW-1/4-VALVE		Needle valve, brass - 1/4"
	HDW-25-CNG		Pipe nipple, steel - 1/4" x 7/8"
N-AL445 N-AC980	Muffler, plastic Muffler, metal		
4 HP	MTR-4-FOOT-AIR N-K208	Foot Mount - 4 HP (6AM-FRV-5A) bi-rotational Repair Kit* (6AM-FRV-5A)	
	MTR-4-56C-AIR N-K208	56C Mount - 4 HP (6AM-NRV-11A) bi-rotational Repair Kit* (6AM-NRV-11A)	
	HDW-1/2-VALVE	Needle valve, brass - 1/2"	
	HDW-50-CNG	Pipe nipple, steel - 1/2" x 1-1/8"	
	N-AC990	Muffler, metal	
	* Repair Kits include: Vanes, shaft seal, o-rings, DE & NDE bearings, body & end cap gaskets.		
	Electric Motors	1/4 HP	MTR-1/4-56C-1-EP
MTR-1/4-56F-1-EP			56F, fixed speed 1/4 HP Explosion-Proof 115/230VAC 1-phase
MTR-1/4-56C-1-TEFC			56C, fixed speed 1/4 HP TEFC 115/230VAC 1-phase
MTR-1/4-56F-1-TEFC			56F, fixed speed 1/4 HP TEFC 115/230VAC 1-phase
CPG-INLINE-18/3			Cord 18/3 - 6', plug and in-line ON-OFF switch
1/3 HP		MTR-1/3-56C-1-EP	56C, fixed speed 1/3 HP Explosion-Proof 115/230VAC 1-phase
		MTR-1/3-56F-1-EP	56F, fixed speed 1/3 HP Explosion-Proof 115/230VAC 1-phase
		MTR-1/3-56C-1-TEFC	56C, fixed speed 1/3 HP TEFC 115/230VAC 1-phase
		MTR-1/3-56F-1-TEFC	56F, fixed speed 1/3 HP TEFC 115/230VAC 1-phase
		CPG-INLINE-18/3	Cord 18/3 - 6', plug and in-line ON-OFF switch
		MTR-098004	56C, variable speed 1/3 HP TEFC 115VAC to 90VDC 1-phase
		MTR-DC-CONTROL CPG-18/3 MET-VSO-BRACKET	DC motor controller, variable speed - 1/3 thru 2HP Cord 18/3 - 6' with plug Angle brackets, mounts v.s. controller to motor (2 req'd)
1/2 HP		MTR-1/2-56C-1-EP	56C, fixed speed 1/2 HP Explosion-Proof 115/230VAC 1-phase
		MTR-1/2-56F-1-EP	56F, fixed speed 1/2 HP Explosion-Proof 115/230VAC 1-phase
		MTR-1/2-56C-1-TEFC	56C, fixed speed 1/2 HP TEFC 115/230VAC 1-phase
		MTR-1/2-56F-1-TEFC	56F, fixed speed 1/2 HP TEFC 115/230VAC 1-phase
		CPG-INLINE-18/3	Cord 18/3 - 6', plug and in-line ON-OFF switch
		MTR-098000	56C, variable speed 1/2 HP TEFC 115VAC to 90VDC 1-phase
	MTR-DC-CONTROL CPG-18/3 MET-VSO-BRACKET	DC motor controller, variable speed - 1/3 thru 2HP Cord 18/3 - 6' with plug Angle brackets, mounts v.s. controller to motor (2 req'd)	

Parts List - Drive Motors (continued)

NOTE: 56F "foot mount" models = CL4-T/E, CL3-T/E, CL5-T/E, CL7-T/E, CL1-T/E only.
56C "C-face mount" models = All other CL and CLG.

Item 100	Part No.	Description					
Electric Motors	3/4 HP	MTR-3/4-56C-1-EP	56C, fixed speed	3/4 HP Explosion-Proof	115/230VAC	1-phase	
		MTR-3/4-56F-1-EP	56F, fixed speed	3/4 HP Explosion-Proof	115/230VAC	1-phase	
		MTR-3/4-56C-1-TEFC	56C, fixed speed	3/4 HP TEFC	115/230VAC	1-phase	
		MTR-3/4-56F-1-TEFC	56F, fixed speed	3/4 HP TEFC	115/230VAC	1-phase	
		CPG-14/3	Cord 14/3 - 5' with plug				
		SWT-TOGGLE	ON - OFF switch				
		SWT-GUARD	Switch guard				
		MTR-108018	56C, variable speed	3/4 HP TEFC	115VAC to 90VDC	1-phase	
		MTR-DC-CONTROL	DC motor controller, variable speed - 1/3 thru 2HP				
		CPG-14/3	Cord 14/3 - 5' with plug				
	MET-VSO-BRACKET	Angle brackets, mounts v.s. controller to motor (2 req'd)					
	1 HP	MTR-1-56C-1-EP	56C, fixed speed	1 HP Explosion-Proof	115/230VAC	1-phase	
		MTR-1-56F-1-EP	56F, fixed speed	1 HP Explosion-Proof	115/230VAC	1-phase	
		MTR-1-56C-1-TEFC	56C, fixed speed	1 HP TEFC	115/230VAC	1-phase	
		MTR-1-56F-1-TEFC	56F, fixed speed	1 HP TEFC	115/230VAC	1-phase	
		CPG-14/3	Cord 14/3 - 5' with plug				
		SWT-DP-TOGGLE	ON - OFF switch				
		SWT-GUARD	Switch guard				
		MTR-108022	56C, variable speed	1 HP TEFC	115VAC to 90VDC	1-phase	
MTR-DC-CONTROL		DC motor controller, variable speed - 1/3 thru 2HP					
CPG-14/3		Cord 14/3 - 5' with plug					
MET-VSO-BRACKET	Angle brackets, mounts v.s. controller to motor (2 req'd)						
1.5 HP	MTR-1.5-56C-1-EP	56C, fixed speed	1.5 HP Explosion-Proof	115/230VAC	1-phase		
	MTR-1.5-56C-1-TEFC	56C, fixed speed	1.5 HP TEFC	115/230VAC	1-phase		
	CPG-14/3	Cord 14/3 - 5' with plug					
	SWT-DP-TOGGLE	ON - OFF switch					
	SWT-GUARD	Switch guard					
	MTR-108092	56C, variable speed	1.5 HP TEFC	230VAC to 180VDC	1-phase		
	MTR-DC-CONTROL	DC motor controller, variable speed - 1/3 thru 2HP					
CRD-CORD	Cord 12/3 - 4' no plug						
MET-VSO-BRACKET	Angle brackets, mounts v.s. controller to motor (2 req'd)						
2 HP	MTR-2-56C-3-EP	56C, fixed speed	2 HP Explosion-Proof	230/460VAC	3-phase		
	MTR-2-56C-3-TEFC	56C, fixed speed	2 HP TEFC	230/460VAC	3-phase		
	MTR-128001	145TC, variable speed	2 HP TEFC	230VAC to 180VDC	1-phase		
	MTR-DC-CONTROL	DC motor controller, variable speed - 1/3 thru 2HP					
	CRD-CORD	Cord 12/3 - 4' no plug					
MET-VSO-BRACKET	Angle brackets, mounts v.s. controller to motor (2 req'd)						
3 HP	MTR-3-140TC-3-EP	140TC, fixed speed	3 HP Explosion-Proof	230/460VAC	3-phase		
	MTR-3-56C-3-TEFC	56C, fixed speed	3 HP TEFC	230/460VAC	3-phase		
	MTR-108502	145TC, variable speed	3 HP TEFC	230VAC to 180VDC	1-phase		
	MTR-DC-CONTROL-3HP	DC motor controller, variable speed - 3HP					
	CRD-CORD	Cord 12/3 - 4' no plug					
MET-VSO-BRACKET	Angle brackets, mounts v.s. controller to motor (2 req'd)						

Parts List - CL & CLG Series Mixer

CL Direct Drive

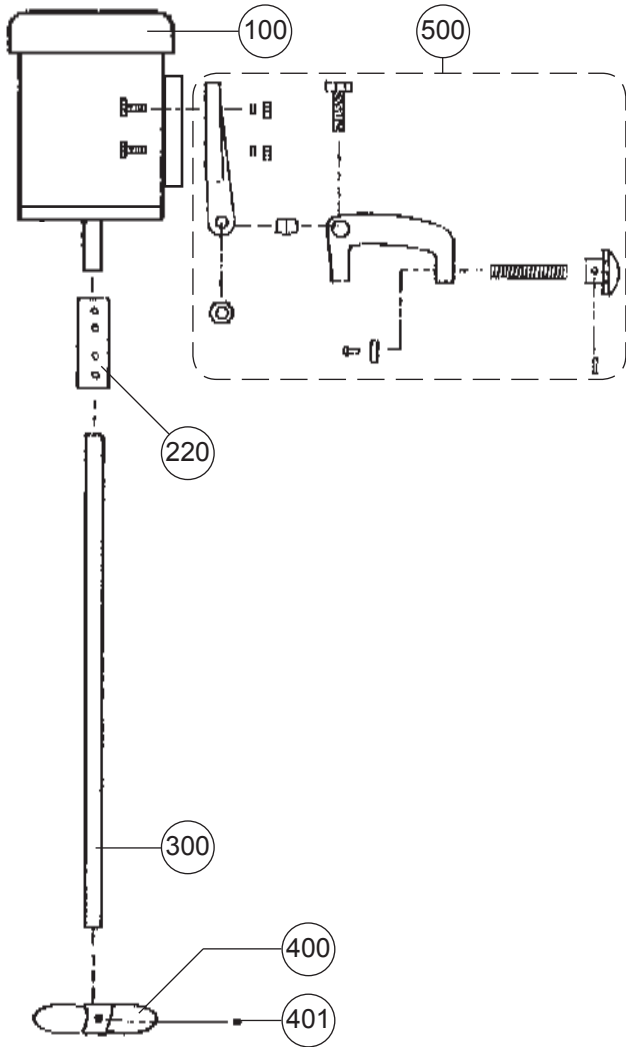

CLG Gear Drive

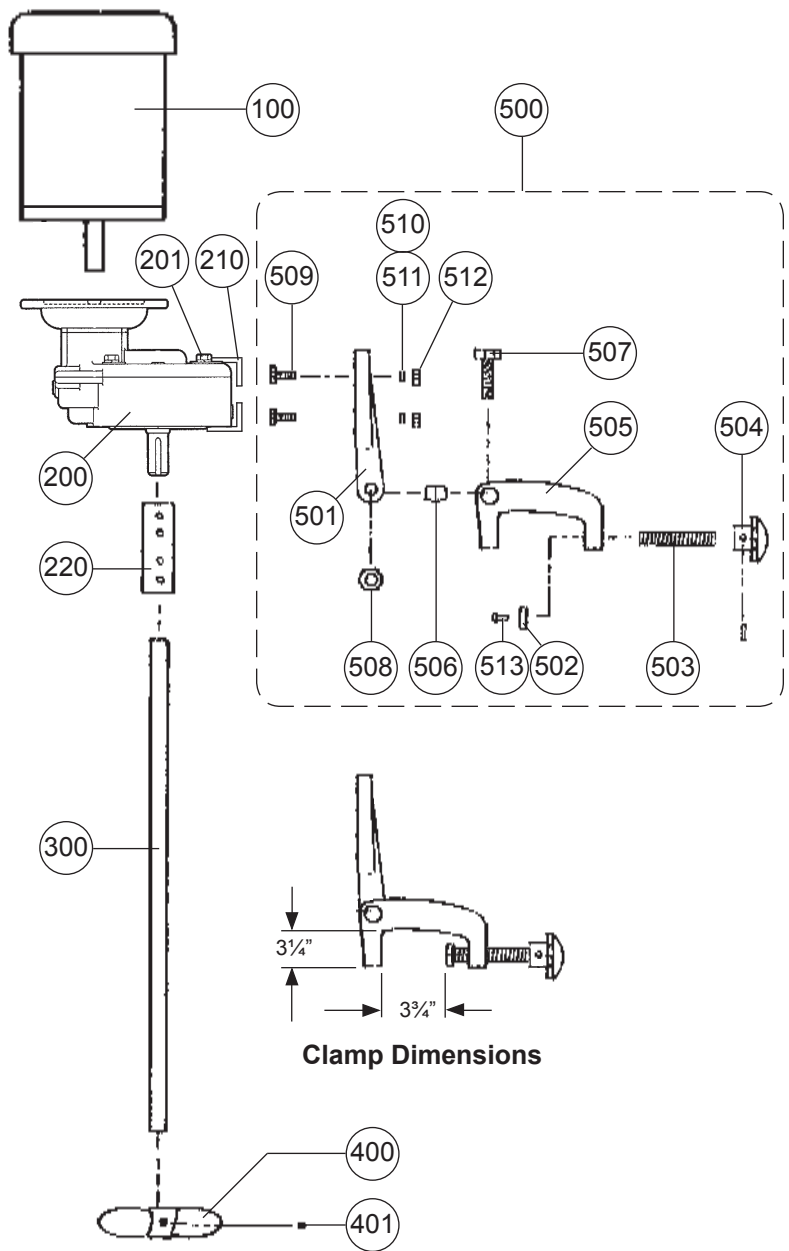

Parts List - CL & CLG Series Mixer

Item	Description	Part No.	Qty.
100.	Motor, air	see 'Parts List - Drive Motors'	1
100.	Motor, electric	see 'Parts List - Drive Motors'	1
200.	Gear Box, 5:1 ratio	HDW-GB-56C	1
201.	Vent, 1/4" MNPT - brass (for HDW-GB-56C only)	HDW-4704-0004	1
200.	Gear Box, 5:1 ratio for: CLG-4A only	HDW-GB-56C-LG	1
210.	Mounting feet, gear box to clamp bracket	MNT-GB-56C-FEET	1
220.	Coupling - shaft, 1/2" bore x 5/8" bore - stainless	CPL-5062	1
220.	Coupling - shaft, 5/8" bore x 5/8" bore - stainless	CPL-6262	1
220.	Coupling - shaft, 5/8" bore x 3/4" bore - stainless	CPL-6275	1
300.	Shaft - impeller, 1/2" dia. x 32" long - stainless	SS132	1
300.	Shaft - impeller, 5/8" dia. x 32" long - stainless	SS632	1
300.	Shaft - impeller, 5/8" dia. x 36" long - stainless	SS636	1
300.	Shaft - impeller, 3/4" dia. x 48" long - stainless	N-SHF-7548	1
400.	Impellers	specify model	1~2
401.	Set screw	specify model	2~4
"C" Clamp Assembly:			
500.	C-Clamp Ass'y Complete - CL models	N-CLPA-CL	1
500.	C-Clamp Ass'y Complete - CLG models	N-CLPA-CLG	1
500.	C-Clamp Ass'y Complete - CL4-A model only <i>consisting of:</i>	N-CLPA-CL-A	1
501.	Motor plate - cast aluminum	MTR-PL-GA	1
502.	Swivel pad - steel	HDW-CSP-1	1
503.	Threaded rod, 5/8" x 7.5" long - zinc plated	SHF-TR6275	1
504.	Hand knob - cast aluminum	HDW-HK42	1
505.	"C" clamp - cast aluminum	CLP-C	1
506.	Clamp connector - steel	CLP-CONN	1
507.	Hex head bolt, 1/2"-13 x 4" - zinc plated	N-HARDWARE	1
508.	Hex nut, 1/2"-13 - zinc plated	N-HARDWARE	1
509.	Hex head bolt, 1/4"-20 x 1.25" - zinc plated	N-HARDWARE	4
510.	Flat washer, 1/4" - zinc plated	N-HARDWARE	4
511.	Lock washer, 1/4" - zinc plated	N-HARDWARE	4
512.	Hex nut, 1/4"-20 - zinc plated	N-HARDWARE	4
513.	Drive screw pin, #14 x 3/4" - zinc plated	N-HARDWARE	1