

CL5-T



CLG-5A



CL-Series & CLG-Series Clamp Mount Mixers

CLAMP MOUNT

After installing the impeller(s) and impeller-shaft which have to be fitted to the machine before it's operational, lower mixer into the container and lock in place with clamp assembly. Ensure the clamp is level, square, and plumb when mounted to the mixing tank. Ensure there is adequate space around the unit for cleaning, inspection and maintenance.

Illustrations below show the ideal operating angles for the CL(G) series portable clamp-mount mixers.

- The mixing shaft should be 10° to 20° off vertical.

IMPELLER PLACEMENT

For mixers with ONE impeller, mount it 1 impeller diameter distance off the bottom of mixing container.

For mixers with TWO or more impellers, mount the lowest impeller 1 impeller diameters distance off the bottom of mixing container. Mount the other impellers 2 impeller diameters apart. The uppermost impeller should be positioned approximately 1 impeller diameter under the surface of the liquid.

The above guide-lines are “rules of thumb” and may not be the best for your situation. Experimenting with impeller placement may provide your best results.

IMPELLERS

The standard impellers are 3-bladed marine style. To install the propeller, back off the set screw(s) as far as possible without removing them. Insert mixing shaft into the bore and tighten the set screw(s) firmly to secure the shaft to the propeller.

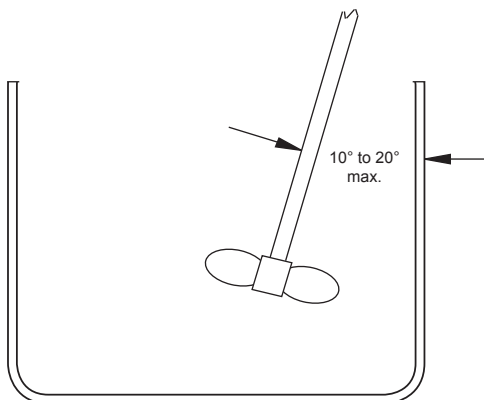

**Off Vertical Mounting
CL & CLG Series**

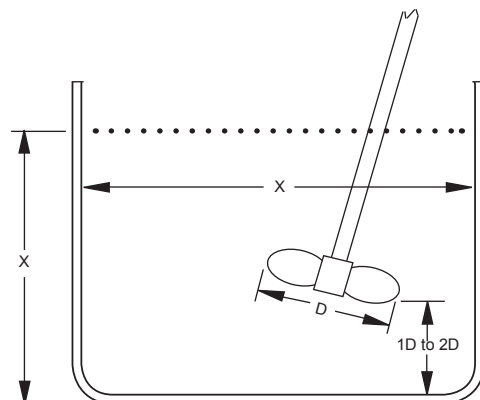

**Impeller Placement
CL & CLG Series**